

## ALLOCATING STORAGE SPACES FOR TEMPORARY INVENTORIES CONSIDERING HANDLING, TRANSPORTATION, AND STORAGE CAPACITIES

Seung Hwan Won and Kap Hwan Kim

*Department of Industrial Engineering, Pusan National University*

*30 Jangjeon-dong, Geumjeong-gu, Busan 609-735, South Korea*

*{shwon, kapkim}@pusan.ac.kr*

### ABSTRACT

Space may be a scarce resource in manufacturing shops, warehouses, freight terminals, and container terminals. This paper discusses how to locate temporary storage inventories in limited storage areas. A typical inventory is delivered from the location of the preceding process to the storage area and stored in the storage area during a certain period of time. It may then be relocated from the original storage position to another storage position. Finally, it is delivered from the final storage area to the location of the next process. Because this logistic process for an inventory requires handling activities, transportation activities, and storage spaces, the limitation in capacities of handling equipment, transportation equipment, and storage space must be considered when allocating spaces to the inventory. This problem is modeled as a multicommodity minimal cost flow problem. A numerical example is presented to validate the model.

**Key Words:** *Space Allocation, Multicommodity Network Flow Problem, Inventory, Container Terminal.*

### 1. INTRODUCTION

Space may be a scarce resource in such storage systems as stock rooms in manufacturing shops, warehouses, freight terminals, and container terminals. Popular design issues for the storage systems are to determine the number of storage locations to be provided, the method of storing/retrieving products, and the assignment of items to locations (Francis *et al.*, 1992). This paper addresses the storage space allocation problem in which storage requirements are assigned to storage locations in a limited storage area. Decisions on the space allocation must consider the availability of space and the handling capacity of material handling and transportation equipment.

Storage location problems can be classified by the length of the storage period into *permanent storage location problems* and *temporary storage location problems*. The permanent storage location problem is to assign a dedicated storage location to each item permanently. Whenever an item arrives at the storage area, it is stored at the dedicated location. However, the temporary storage location problem is for assigning a temporary storage location to an item. When the same item visits the storage area next time, the new storage location can be assigned to the item.

Works-in-process (WIPs) in manufacturing shops are a typical type of the temporary storage inventory. Larson and Kusiak (1995) addressed the problem to allocate storage spaces to WIPs in manufacturing shops. Containers in container yards are another example of the temporary storage inventory. Kozan (2000) introduced a network model for representing the handling process of containers in seaport container terminals. Nodes of the network represent ships, berthing and marshalling areas, storage areas, multimodal truck terminals, and rail intermodal terminals. The objective was to minimize the total throughput time which is the

sum of the handling and travelling times of containers. He also attempted to determine the type of equipment to handle a specific group of containers and consider the limitation in the storage space. Zhang *et al.* (2003) discussed the storage space allocation problem in storage yards of container terminals. They decomposed the space allocation problem into two levels: the subproblem in the first level attempts to balance workloads among different yard blocks, while the second subproblem minimizes the total transportation distance for moving containers between blocks and vessel berthing locations. Kim and Park (2003) proposed a multicommodity minimal cost flow problem model for the space allocation problem. A subgradient optimization technique was applied to solve the problem. Although they considered the limitation in the storage space, they did not consider the limitation in the handling capacity and the transportation capacity.

Unlike previous studies on the storage space allocation problem, this study considers not only the storage capacity but also the handling capacity of different storage locations and the transportation capacity of the entire storage yard.

Section 2 introduces the storage space allocation problem for temporary inventories. Section 3 provides a mathematical model for the problem. Section 4 discusses a numerical example to validate the model. Finally, section 5 presents a conclusion.

## 2. PROBLEM DESCRIPTION

A *storage activity* is defined as a temporary stay of an inventory at a storage location, which comes from a source process and is bound for a destination process. Source processes include an arrival of an inventory from the outside of storage areas or a preceding process for a WIP. Similarly, destination processes include a departure of an inventory to the outside of storage areas or a succeeding process of a WIP. Between the arrival and the departure of the inventory, it is stored at a storage location for a certain length of time. A zone of a storage area may be reserved in advance for a specific type of inventories before the inventories actually start to arrive at the storage area, in which case the starting time of the storage activity is the moment of the reservation. The finishing time of a storage activity is the moment when the storage spaces, which have been occupied by the storage activity, are released.

We define *periods* as time buckets with the same time interval. The length of a period can be 1 hour, half day, or even longer.

A storage activity includes several subactivities. There are four kinds of subactivities: arrival, stay, relocation, and departure. After an inventory is delivered from the location of the preceding process of the inventory to the storage area (*arrival*), it is stored there during a certain number of periods (*stay*). During the stay, it may be relocated from a storage position to another (*relocation*). Finally, it is delivered to the next process of the inventory (*departure*).

We propose the following assumptions to define a storage activity:

- (1) Space must be available at the beginning of the period when the corresponding inventory arrives at the storage area.
- (2) The arrival (receiving operation) of a storage activity occurs only at the period when the corresponding inventory arrives at the storage area.
- (3) The departure (delivery operation) of a storage activity may occur at more than one period. Space is released at the end of each period when the corresponding inventory leaves the storage area.
- (4) A relocation of an inventory from a storage location to another starts and ends during a period.

Figure 1 illustrates a storage activity. The storage activity in Figure 1 has the arrival at two different locations at period 1. A relocation occurs at period 3. The departure (delivery) begins at period 7 and ends at period 10.

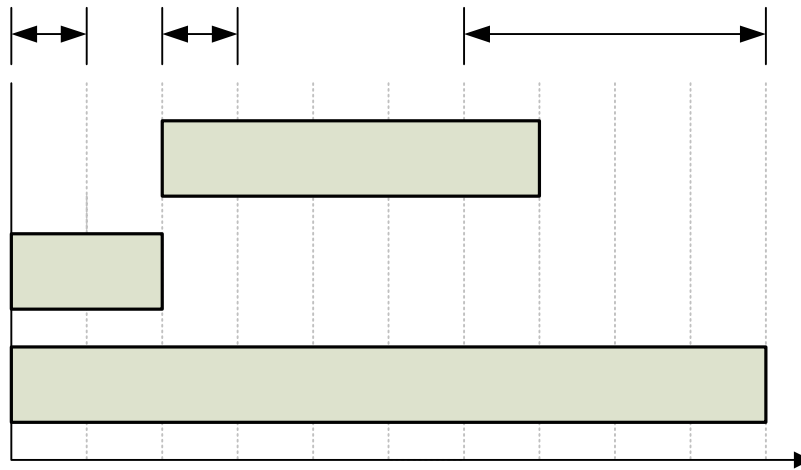

**Figure 1.** An illustration of a storage activity

Figure 2 shows a solution of the space allocation problem for temporary inventories. The number of storage locations is 3 and the number of storage activities is 7. The bars in Figure 2 indicate storage activities. Storage activity 2 starts the arrival at storage location 2 at the beginning of period 2, is stored at storage location 2 from period 2 to period 4. It finishes the departure from storage location 2 at the end of period 4. Contrary to storage activity 2, storage activity 4 moves from one storage location to another during its stay. Storage activity 4 starts the relocation from storage location 3 to storage location 2 at the beginning of period 8.

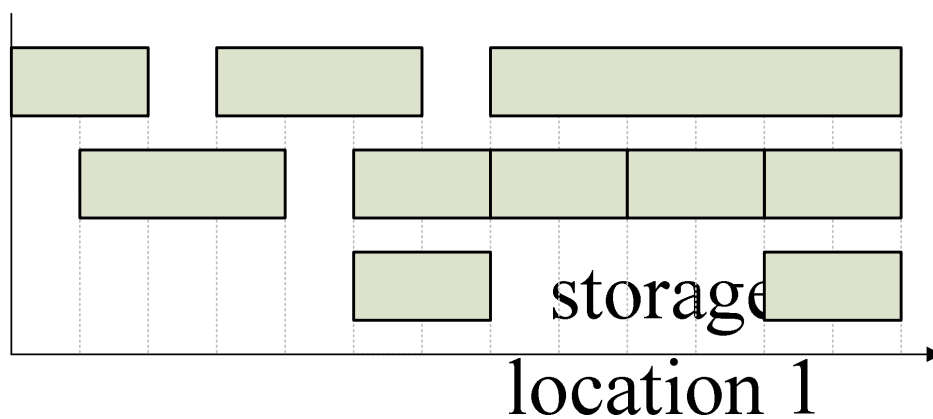

**Figure 2.** A solution for storage space allocation

The subactivities *arrival*, *relocation*, and *departure* give rise to the transportation cost and the handling cost. The subactivity *stay* incurs only the storage cost. Note that subactivity *arrival* cannot last for more than one period, while subactivity *departure* may continue for more than one period. Figure 3 shows the subactivities and their related costs. Subactivity *relocation* also cannot last for more than one period. For relocating inventories from a location to another, the handling cost is incurred at both the former and the latter locations. The storage cost is incurred during the entire storage time while the transportation and the

handling cost are incurred only at the period when the corresponding subactivities are carried out.

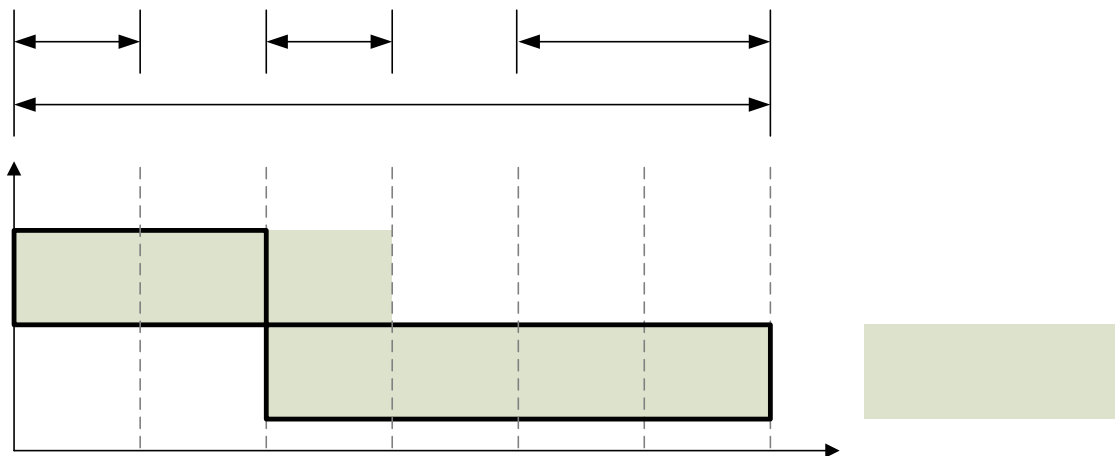

**Figure 3.** Subactivities of a storage activity and related cost items

This study assumes that there exist limitations in capacities of storage, handling, and transportation. Each storage location has its limited capacity of space and handling equipment. The space capacity is represented by the number of unit loads which can be stored in the storage location. And the handling capacity is represented by the standard handling times which the handling equipment in each storage location can provide during one period. The maximum handling time of each storage location depends on the number of the equipment in the location and the performance of the equipment.

The transportation capacity is represented by the total transportation time which the transportation vehicles in the storage area can provide during one period. Assuming that the performances of all transportation vehicles are the same, the transportation capacity can be evaluated by the product of the length of one time bucket, the number of transportation vehicles, and the utilization factor.

The space required for a storage activity is determined by the number of stock keeping units (SKUs) and the size of each SKU, while the transportation time for the storage activity can be estimated by the number of SKUs, the distance of the transportation, and the speed of vehicles. The handling time for a storage activity is evaluated by the number of SKUs and the standard handling time per SKU. The standard handling time per SKU depends on activity types and characteristics of equipment. Table 1 illustrates the expected handling times by yard cranes for different types of handling operations in container terminals (Lee and Kim, 2006).

**Table 1.** An example of expected handling times for operation in container terminals

Operation Type	Expected Handling Times (in minutes)
Receiving	1.521
Loading	1.134
Unloading	1.114
Delivery	2.242

Figure 4 shows the handling loads of each storage location based on the solution in Figure 2. The bars indicate storage activities and the shaded rectangles indicate handling requirements. The number in shaded rectangles indicates the storage activity number. It is assumed that all storage activities require the same handling times and the handling loads are distributed uniformly during one period. Storage location 1 requires one unit of handling

operation at period 1, 2, 4, 6, 8, and 13. Storage location 2 requires one unit of handling operation at period 2, 4, 6, 9, 10, and 13 and two units of handling operations at period 8 and 12. The transportation times required at each period can also be calculated in a similar way.

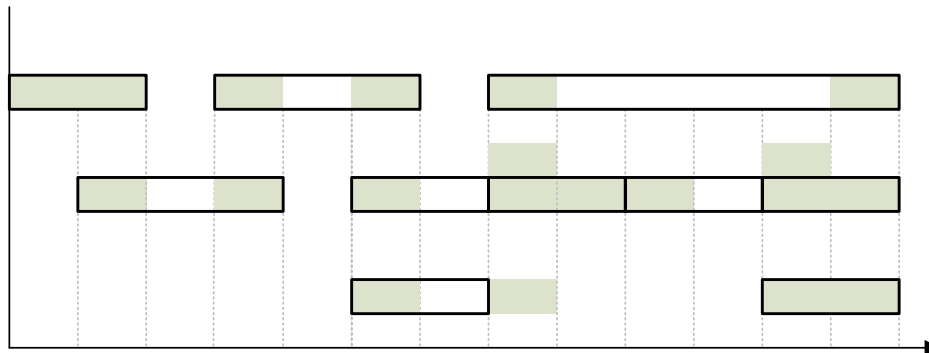

**Figure 4.** Handling loads of each storage location

The problem in this study is to allocate temporary inventories to spaces in storage areas. It is assumed that the inventory to be stored is discrete and in the form of unit loads (e.g., pallet loads, tote boxes, cartons, cases, and containers). The objective of this problem is to minimize the total cost of inventories for a given schedule of arrivals and departures for the inventories. The total cost consists of the transportation cost, the handling cost, and the storage cost. And constraints are related to the storage space, the handling equipment, and the transportation equipment in storage areas.

### 3. MATHEMATICAL FORMULATION

This section proposes a mathematical formulation of the *Space Allocation Problem for temporary inventories considering Handling, Transportation, and Space capacity* (SAPHTS).

The problem can be represented by a multicommodity network flow model as shown in Figure 5. Storage activities are represented by commodities. The network consists of a finite set  $V$  of nodes and a finite set  $E$  of arcs. There are three kinds of nodes: source nodes, sink nodes, and transshipment nodes. Source nodes and sink nodes are represented by shaded circles, and transshipment nodes are represented by transparent circles. First, source nodes,  $S^i$ , only have exiting arcs and correspond to the initiating events of storage activity  $i$ . Second, sink or terminal nodes,  $T^i$ , only have entering arcs and correspond to the terminating events of storage activity  $i$ . Each storage activity has a single source and a single sink. Third, transshipment nodes,  $j^p$ , have both entering and exiting arcs and correspond to storage location  $j$  and period  $p$  of the intermediate event. The arcs from source nodes to transshipment nodes represent subactivity *arrival*, the horizontal arcs between transshipment nodes in the same storage location represent subactivity *stay*, the vertical arcs between transshipment nodes in the same period represent subactivity *relocation*, and the arcs from transshipment nodes to sink nodes represent subactivity *departure*. The arcs from source nodes to transshipment nodes, the arcs between transshipment nodes in the same storage location, and the arcs from transshipment nodes to sink nodes have capacity limitations imposed by limited handling capacities. The arcs between transshipment nodes in the same location have capacity limitations imposed by on space capacities. The objective is to determine a minimal cost multicommodity flow through the network that meets the demand for each commodity and space, transportation, and handling capacity constraints. The problem of this class is called *multicommodity minimal cost flow problem* (MMCFP). MMCFP arises when several items (commodities) share arcs in

a capacitated network (Kennington, 1978). Practical examples of MMCFP are communication systems, urban traffic systems, railway systems, multiproduct production-distribution systems, and military logistics systems. MMCFP has been extensively studied because of its numerous applications and intriguing network structure.

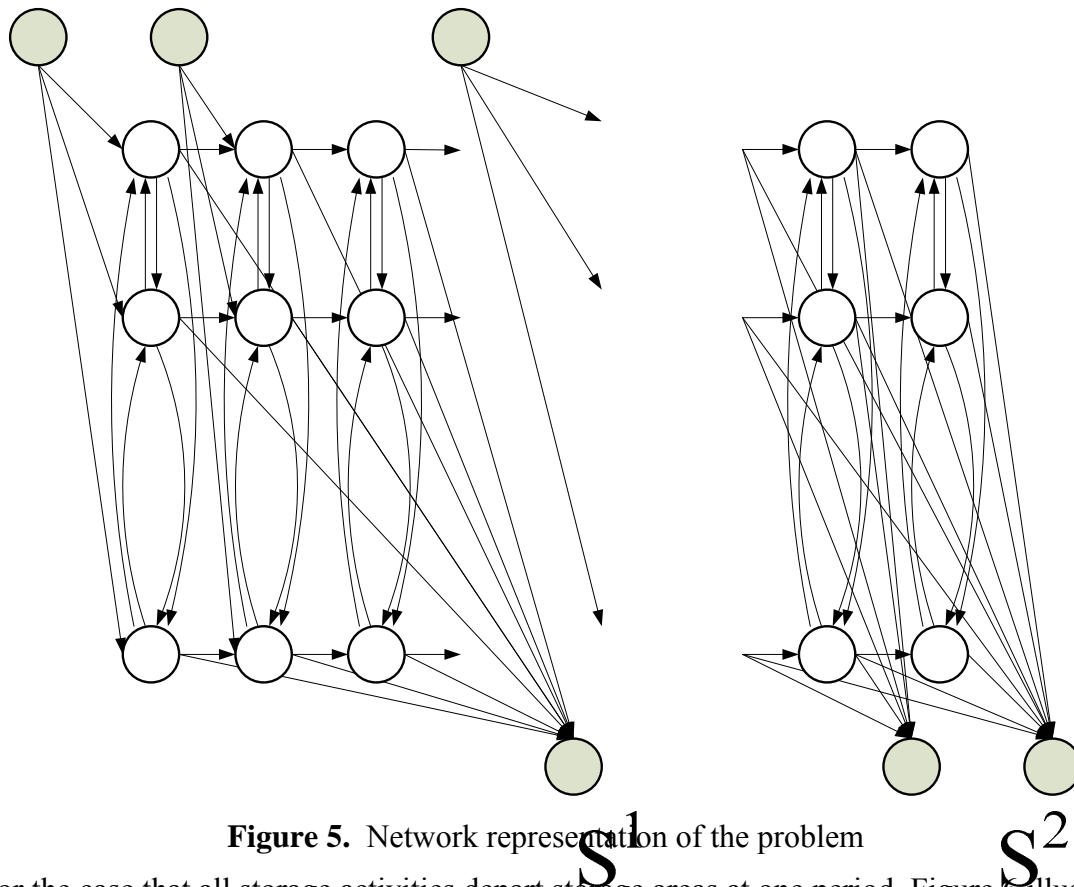

**Figure 5.** Network representation of the problem

For the case that all storage activities depart storage areas at one period, Figure 6 illustrates a solution for the example in Figure 2.

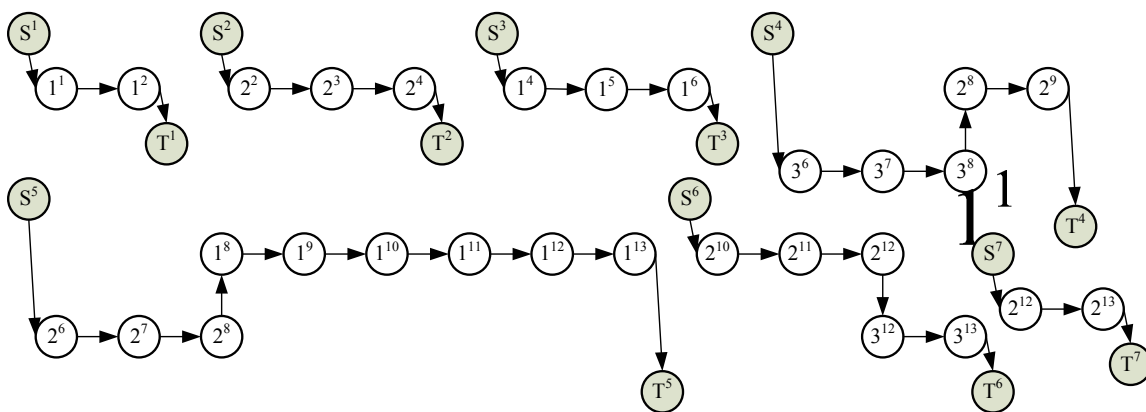

**Figure 6.** An illustration of a solution

The following notations are used for a mathematical formulation.

**Indices:**

- $i$  The index for storage activities where  $i = 1, 2, \dots, I$ .
- $j$  The index for storage locations where  $j = 0, 1, \dots, J+1$ . Storage location 0 indicates a preceding process of the storage activity, while storage location  $J+1$  represents the next

$p$  process of the storage activity.  
 The index for periods where  $p = 1, 2, \dots, P$ .

**Problem data:**

$c_i^{uv}$  The cost incurred when an SKU for storage activity  $i$  is delivered from storage location  $u$  to storage location  $v$ . When  $v = u$ , it corresponds to storage costs, while, when  $v \neq u$ , it corresponds to the sum of transportation and handling costs.

$d_i$  The number of SKUs required for storage activity  $i$ . This amount corresponds to the total flow that must be sent from source node ( $S^i$ ) to sink node ( $T^i$ ) in Figure 5.

$s_i$  The starting period of storage activity  $i$ .

$f_i$  The finishing period of storage activity  $i$ .

$r_{ip}$  The departure ratio of storage activity  $i$  during period  $p$ . Period  $p$  is between  $s_i$  and  $f_i$ . The sum of the departure ratios over multiple periods for a storage activity is one.

$\gamma_i$  The number of periods in which  $r_{ip} > 0$ .  $r_{ip} > 0$  for  $p = f_i - \gamma_i + 1, f_i - \gamma_i + 2, \dots, f_i$ .

$\omega_{iw}^{uv}$  The handling time for the equipment in storage location  $w$  to move an SKU for storage activity  $i$  from storage location  $u$  to storage location  $v$ . Storage location  $w$  is either storage location  $u$  or  $v$ .

$\tau^{uv}$  The transportation time for vehicles to move an SKU from storage location  $u$  to  $v$ .

$S_j$  The space capacity of storage location  $j$ .

$H_j$  The handling capacity of storage location  $j$  in handling time.

$T$  The transportation capacity of the storage area in transportation time.

**Decision variables:**

$X_{ip}^{uv}$  The amount of storage activity  $i$  that moves from storage location  $u$  to  $v$  at the beginning of period  $p$ . When  $v = u$ , the storage inventory stays at the same location during period  $p$ .

SAPHTS can be formulated as follows:

$$\text{Minimize } \sum_{i=1}^I \sum_{u=0}^J \sum_{v=1}^{J+1} \sum_{p=1}^P c_i^{uv} X_{ip}^{uv}, \tag{1}$$

subject to

$$\sum_{v=1}^J X_{is_i}^{0v} = d_i \text{ for } i = 1, 2, \dots, I, \tag{2}$$

$$-\sum_{u=1}^J X_{ip}^{u(J+1)} = -r_{ip} d_i \text{ for all } (i, p) \text{ where } i = 1, 2, \dots, I \text{ and } p = s_i + 1, s_i + 2, \dots, f_i, \tag{3}$$

$$X_{is_i}^{jj} - X_{is_i}^{0j} = 0 \text{ for all } (i, j) \text{ where } i = 1, 2, \dots, I \text{ and } j = 1, 2, \dots, J, \tag{4}$$

$$X_{ip}^{jj} + \sum_{v=1}^J X_{ip}^{jv} - X_{i(p-1)}^{jj} - \sum_{u=1}^J X_{ip}^{uj} = 0 \text{ for all } (i, j, p) \tag{5}$$

where  $i = 1, 2, \dots, I, j = 1, 2, \dots, J$ , and  $p = s_i + 1, s_i + 2, \dots, f_i - \gamma_i$ ,

$$X_{ip}^{j(J+1)} + X_{ip}^{jj} - X_{i(p-1)}^{jj} = 0 \text{ for all } (i, j, p) \tag{6}$$

where  $i = 1, 2, \dots, I, j = 1, 2, \dots, J$ , and  $p = f_i - \gamma_i + 1, f_i - \gamma_i + 2, \dots, f_i - 1$ ,

$$X_{if_i}^{j(J+1)} - X_{i(f_i-1)}^{jj} = 0 \text{ for all } (i, j) \text{ where } i = 1, 2, \dots, I \text{ and } j = 1, 2, \dots, J, \tag{7}$$



$$\sum_{i=1}^I \sum_{v=1}^J X_{ip}^{jv} \leq S_j \text{ for all } (j, p) \text{ where } j=1, 2, \dots, J \text{ and } p=1, 2, \dots, P, \quad (8)$$

$$\sum_{i=1}^I \sum_{u=0(u \neq j)}^J \omega_{ij}^{uj} X_{ip}^{uj} + \sum_{i=1}^I \sum_{v=1(v \neq j)}^{J+1} \omega_{ij}^{jv} X_{ip}^{jv} \leq H_j$$

for all  $(j, p)$  where  $j=1, 2, \dots, J$  and  $p=1, 2, \dots, P,$  (9)

$$\sum_{i=1}^I \sum_{u=0}^J \sum_{v=1(v \neq u)}^{J+1} \tau^{uv} X_{ip}^{uv} \leq T \text{ for } p=1, 2, \dots, P, \quad (10)$$

$X_{ip}^{uv} \geq 0$  and integer for all  $(i, u, v, p)$   
 where  $i=1, 2, \dots, I, u=0, 1, \dots, J, v=1, 2, \dots, J+1,$  and  $p=1, 2, \dots, P.$  (11)

The objective function (1) is to minimize the total cost of all storage activities. Constraints (2)-(6) represent the flow conservation or mass balance. In constraints (2)-(6), the left side represents flow amounts on nodes and the right side represents balancing amounts. The positive values in the flow indicate outflow amounts and the negative values in the flow indicate inflow amounts. Constraint (2) represents the flow conservation in source nodes. The balancing amount in source nodes is the total amount required for each storage activity because source nodes have only exiting arcs. Constraint (2) means that the total outflow amount from source node  $i$  at the starting period of storage activity  $i$  equals to the total amount required for storage activity  $i$ . Constraint (3) represents the flow conservation on sink nodes. The balancing amount in sink nodes is the negative value of the total amount required for each storage activity, because sink nodes have only entering arcs. Constraint (3) means that the total inflow amount to sink node  $i$  at period  $p$  equals to the product of the departure ratio and the total required amount. This constraint is valid only for the duration of each storage activity. Constraints (4)-(7) represent the flow conservation in transshipment nodes. The balancing amount in transshipment nodes is zero, because transshipment nodes have both exiting arcs and entering arcs. The flow conservation in the transshipment nodes is illustrated in Figure 7. The terms ①, ②, and ③ in Figure 7 are outflow amounts and the terms ④, ⑤, and ⑥ are inflow amounts. Constraint (4) implies that no relocation happens where and when the arrival of each storage activity occurs. Similarly, constraints (6) and (7) imply that no relocation happens where and when the departure of each storage activity occurs. Since subactivities *arrival* or *departure* already consume one period, that storage activity cannot require additional resources through relocations. Constraint (8) represents the space constraint, which restricts the total amounts of all the storage activities on each storage location at all periods to at most space capacity in each storage location. Note that subactivity *relocation* requires the space capacity of the origin storage location at the period with relocations. The case of  $v = j$  corresponds to subactivity *stay* and the case of  $v \neq j$  corresponds to subactivity *relocation*. Constraint (9) represents the handling constraint, which restricts the total handling times at each storage location. Constraint (10) represents the transportation constraint, which restricts the total transportation times required for all the storage activities.



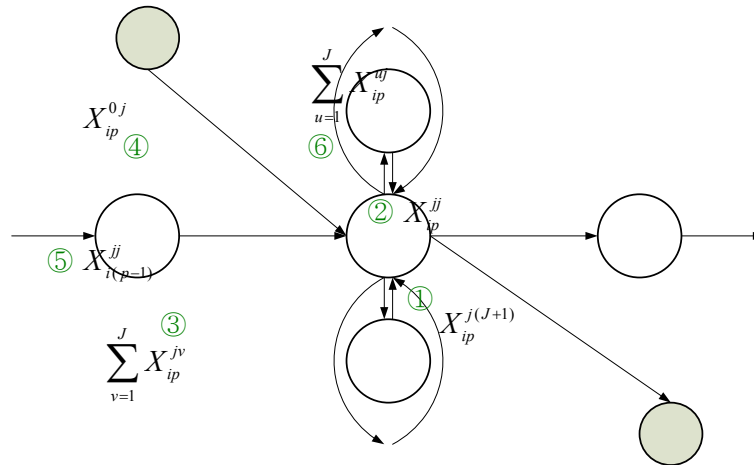

Figure 7. Various flows on a node

#### 4. NUMERICAL EXAMPLE

There are many instances to apply the proposed model in the real life. Manufacturing job shops are typical examples. A shop usually consists of multiple workstations and multiple storage locations. Products are processed in workstations and transferred between workstations according to their routing information. Temporary inventories between workstations can be stored in a storage area. Products are moved from a preceding process to a storage area, stored in the storage area, and moved from the storage area to the next process.

Another example can be observed in container terminals. The yard in container terminals is a large-scale storage area. There exist various flows of containers among ships, gates, rails, and freight stations. Compared with manufacturing environments, the discharging of containers from one transportation mode corresponds to the arrival of inventories from the preceding process and the loading of containers into another transportation mode corresponds to the departure of WIPs to the next process. Containers are stored in the yard in order to be transhipped between transportation modes.

An example is provided to illustrate the model in the following. Figure 8 shows a schematic layout of the storage area and the related processes used in the example. The storage area consists of 9 storage locations and 5 processes (P1, P2, P3, P4, and P5) are located around the storage area. The distances between storage locations and the distances between processes and storage locations are given in Table 2 and Table 3, respectively. The length of a period is 1,440 minutes or 1 day. The space capacity of each storage location is equally set to 960 units, the handling capacity of each storage location is equally set to 2,736 minutes per period, and the transportation capacity of the storage area is 41,472 minutes per period. The calculation procedure is given as follows:

- (1) Space capacity = (number of tiers) × (number of rows) × (number of bays) × (utilization)  
 = 4 × 6 × 50 × 80%  
 = 960 (units),
- (2) Handling capacity = (length of one period) × (number of equipment) × (availability)  
 = 1,440 minutes × 2 × 95%  
 = 2,736 minutes,
- (3) Transportation capacity = (length of one period) × (number of equipment) × (availability)  
 = 1,440 minutes × 36 × 80%

= 41,472 minutes.

We also assume that the speed of transportation vehicles is 360 m/min.

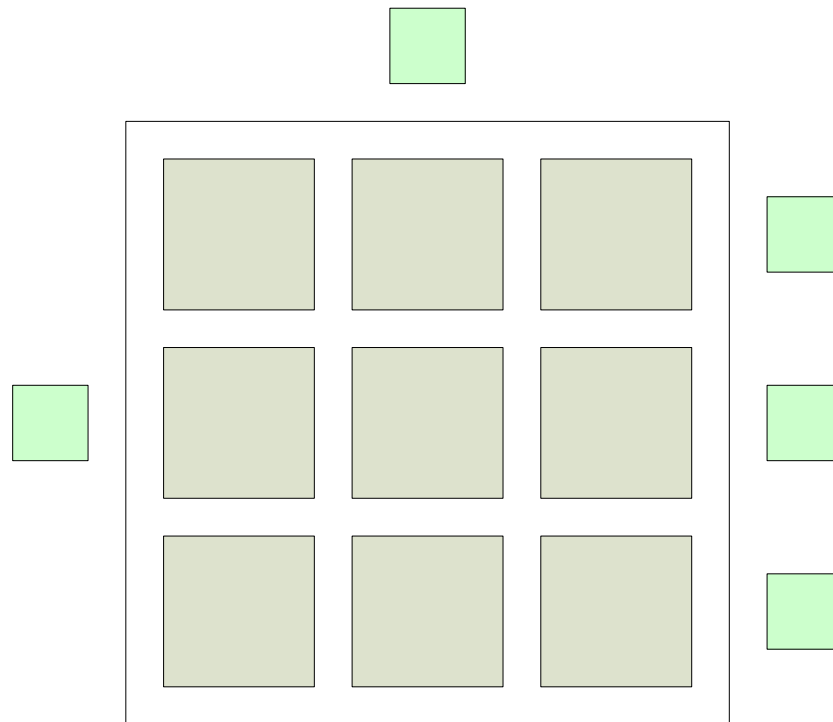

**Figure 8.** A schematic layout of the storage area and the related processes

**Table 2.** Distances between storage locations (unit: m)

Storage Location	1	2	3	4	5	6	7	8	9
1	-	250	500	250	500	750	500	750	1,000
2	250	-	250	500	250	500	750	500	750
3	500	250	-	750	500	250	1,000	750	500
4	250	500	750	-	250	500	250	500	750
5	500	250	500	250	-	250	500	250	500
6	750	500	250	500	250	-	750	500	250
7	500	750	1,000	250	500	750	-	250	500
8	750	500	750	500	250	500	250	-	250
9	1,000	750	500	750	500	250	500	250	-

**Table 3.** Distances between processes and storage locations (unit: m)

Storage Location	1	2	3	4	5	6	7	8	9
Process									
P1	750	500	250	1,000	750	500	1,250	1,000	750
P2	1,000	750	500	750	500	250	1,000	750	500
P3	1,250	1,000	750	1,000	750	500	750	500	250
P4	500	250	500	750	500	750	1,000	750	1,000
P5	500	750	1,000	250	500	750	500	750	1,000

Table 4 shows storage activities and their attributes. The activity type in the second column indicates the types of subactivity *arrival* and *departure*. There are three kinds of activity types: RL, UD, and UL. The first character of activity types is related to subactivity *arrival* and the second character of activity types is related to subactivity *departure*. R, D, U, and L represent receiving, delivery, unloading, and loading operation, respectively. For example,

‘RL’ indicates that the receiving and the loading operation must be carried out at the moment of arrival and departure of the corresponding storage activity, respectively. The departure proportion in the seventh column indicates the ratio of the SKUs departing the storage area at each period. The size of digits is equal to the length of the storage period and each digit represents the proportion of departure at each period. Consider storage activity *1* as an example. The string, ‘0055’, means that no SKU departs the storage area at period *1* and *2* and 50% of total SKUs depart the storage area at each of period *3* and *4*. The character ‘A’ indicates 100%. The handling time of each operation in Table 1 was used. Because handling operations in origin storage locations are similar to loading operations and handling operations in destination storage locations are similar to receiving operations in subactivity *relocation*, LR or loading and receiving was added to the list of activity types.

**Table 4.** Storage activities and their attributes

Storage Activity	Activity Type	Source	Destination	Starting Time (Period)	Finishing Time (Period)	Departure Proportion	No. of SKUs
1	UL	P1	P3	1	4	0055	1,050
2	UD	P1	P4	6	8	055	600
3	UL	P1	P3	10	11	0A	900
4	UD	P2	P4	1	3	055	600
5	UL	P2	P3	5	9	00055	1,200
6	UD	P3	P5	1	4	000A	900
7	UD	P3	P4	7	12	002233	1,200
8	RL	P4	P1	3	8	000055	1,500
9	RL	P4	P2	1	2	0A	450
10	RL	P4	P3	6	12	0000055	1,500
11	UL	P1	P2	4	5	0A	300
12	UL	P2	P3	13	16	0055	900
13	UD	P3	P4	16	20	02233	600
14	RL	P4	P1	11	17	0000055	1,200
15	RL	P5	P1	9	13	00055	450
16	UL	P1	P2	16	19	0055	750
17	UD	P2	P4	13	15	055	750
18	UD	P3	P5	10	13	000A	600
19	RL	P4	P3	13	16	0055	900
20	RL	P5	P2	18	20	055	600
21	UL	P1	P2	7	13	0000055	600
22	UD	P2	P5	15	19	0000A	300
23	UL	P3	P3	14	17	0055	600
24	RL	P4	P2	12	16	00055	600
25	RL	P4	P3	12	15	0055	300
26	UL	P1	P3	16	18	055	450
27	UD	P2	P5	17	19	00A	900
28	UD	P3	P4	12	13	0A	600
29	RL	P4	P1	16	19	0055	300

The example was solved by ILOG CPLEX 9.0 with a Pentium 4 CPU 3GHz personal computer. The solving time is 5.00 seconds and the optimal cost was 21,315,000. Figure 9 illustrates five storage activities in the optimal solution. Consider storage activity *1* in the upper left corner in Figure 9. The 390 SKUs arrive at storage location 9 at period *1*, are stored for three periods, and depart the storage area at period *3*. The other 660 SKUs arrive at storage location 3 at period *1* and are stored for three periods. Among them, 525 SKUs continues to be stored until period *4* and departs the storage area at period *4*. 135 SKUs depart the storage area at period *3*. The storage activities *6* and *7* experience relocations.

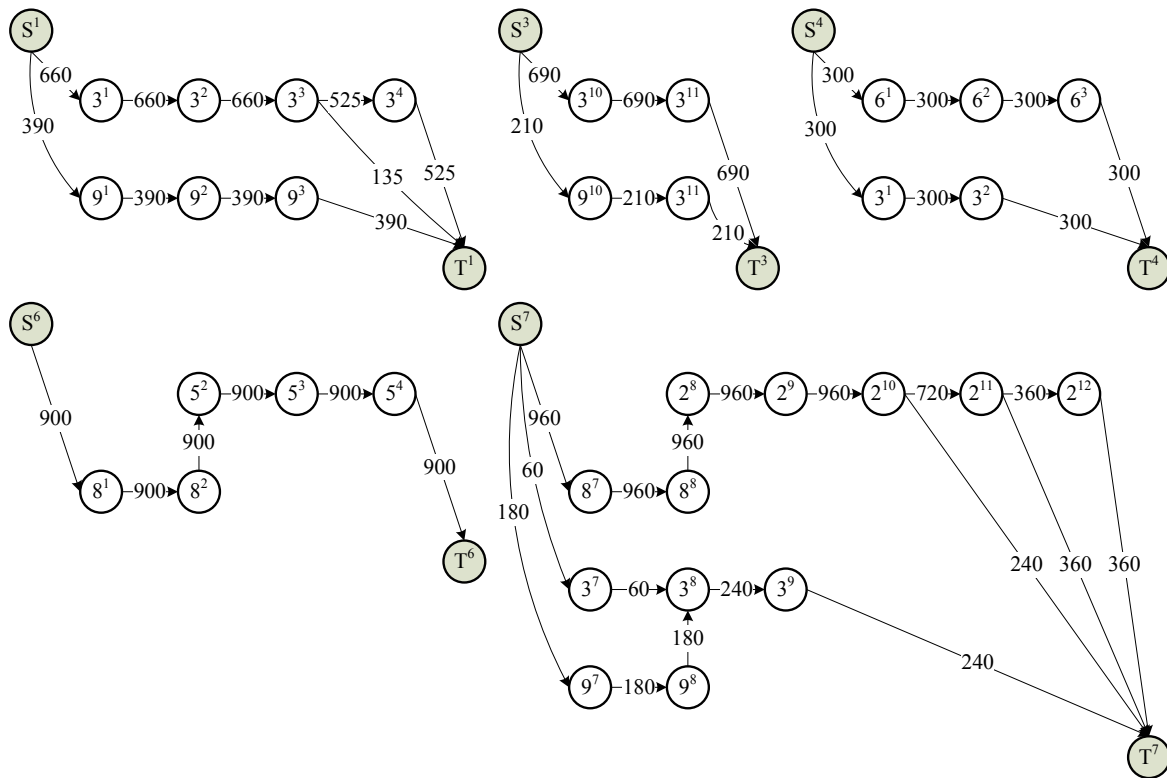

**Figure 9.** Network representation of some storage activities in an optimal solution

## 5. CONCLUSION

This study has described the problem of allocating storage spaces to temporary inventories. We defined storage activities and divided them into four subactivities: *arrival*, *stay*, *relocation*, and *departure*. The problem was represented as multicommodity minimal cost flow problem and formulated as an integer programming model. In the model, the handling capacity, the transportation capacity, and the space capacity in storage areas are considered. Finally, a numerical example was provided.

Multicommodity minimal cost flow problem can be formulated as a linear programming model and may be solved by the simplex method. However, real-world problems in this class are frequently of such size that direct application of the simplex method is prohibitive. Therefore, it is needed to apply specialized techniques developed for multicommodity network flow problems: price-directive decomposition, resource-directive composition, and partitioning methods.

The model presented in this study can be extended to the case where subactivity *arrival* of storage activities can occur for more than one period. The problem to determine the size of one period or a time bucket is another issue for further studies.

## ACKNOWLEDGEMENTS

This work was supported by the Regional Research Centers Program (Research Center for Logistics Information Technology), granted by the Korean Ministry of Education & Human Resources Development.

## REFERENCES

- Ahuja, R. K., Magnanti, T. L. and Orlin, J. B. (1993), *Network Flows: Theory, Algorithms, and Applications*, Prentice Hall, Eaglewood Cliffs, New Jersey.
- Francis, R. L., McGinnis, Jr., L. F. and White, J. A. (1992), *Facility Layout and Location: An Analytical Approach*, Prentice Hall, Eaglewood Cliffs, New Jersey.
- Kennington, J. L. (1978), A Survey of Linear Cost Multicommodity Network Flows, *Operations Research*, **26**, 209-236.
- Kim, K. H. and Park, K. T. (2003), Dynamic Space Allocation for Temporary Storage, *International Journal of Systems Science*, **34**, 11-20.
- Kozan, E. (2000), Optimising Container Transfers at Multimodal Terminals, *Mathematical and Computer Modelling*, **31**, 235-243.
- Larson, N. and Kusiak, A. (1995), Work-In-Process Space Allocation: A Model and an Industrial Application, *IIE Transactions*, **27**, 497-506.
- Lee, B. K. and Kim, K. H. (2006), Estimating Handling Times of Yard Cranes in Container Terminals, Working Paper.
- Vollmann, T. E., Berry, W. L. and Whybark, D. C. (1997), *Manufacturing Planning and Control Systems*, Irwin/McGraw-Hill.
- Zhang, C., Liu, J., Wan, Y.-W., Murty, K. G. and Linn, R. J. (2003), Storage Space Allocation in Container Terminals, *Transportation Research*, **37B**, 883-903.